

INDION® Membrane Systems

Dye Desalting, Concentration & Purification

Ion Exchange offers a wide range of membrane solutions for dye desalting, concentration and purification of the finished products for the dye industry. These include systems designed using HYDRAMEM ultra filtration (UF), reverse osmosis (RO) and nano filtration (NF) membranes. Our solutions not only improve the quality of the finished products, but also improve process efficiency, increase profitability and dispose waste efficiently.

Our advanced membrane systems are commonly applied to reactive dyes, along with other products such as sulphur, direct and acid dyes. They also find applications for food colours & pigment concentration.

Integration of dye desalting, concentration and purification process with downstream zero liquid discharge (ZLD) systems also helps in effluent treatment and importantly recovering 95-98% water.



Features

- Advanced membrane filtration solution resulting in:
 - >95% desalting
 - <0.1% dye loss
 - Increased dye concentration from 5 to 30%
- Modular, skid mounted & automated systems

Benefits

- Significant improvement in product quality
- Increased yield
- Increased dryer throughput/capacity

Integrated dye desalting, concentration & water recovery system

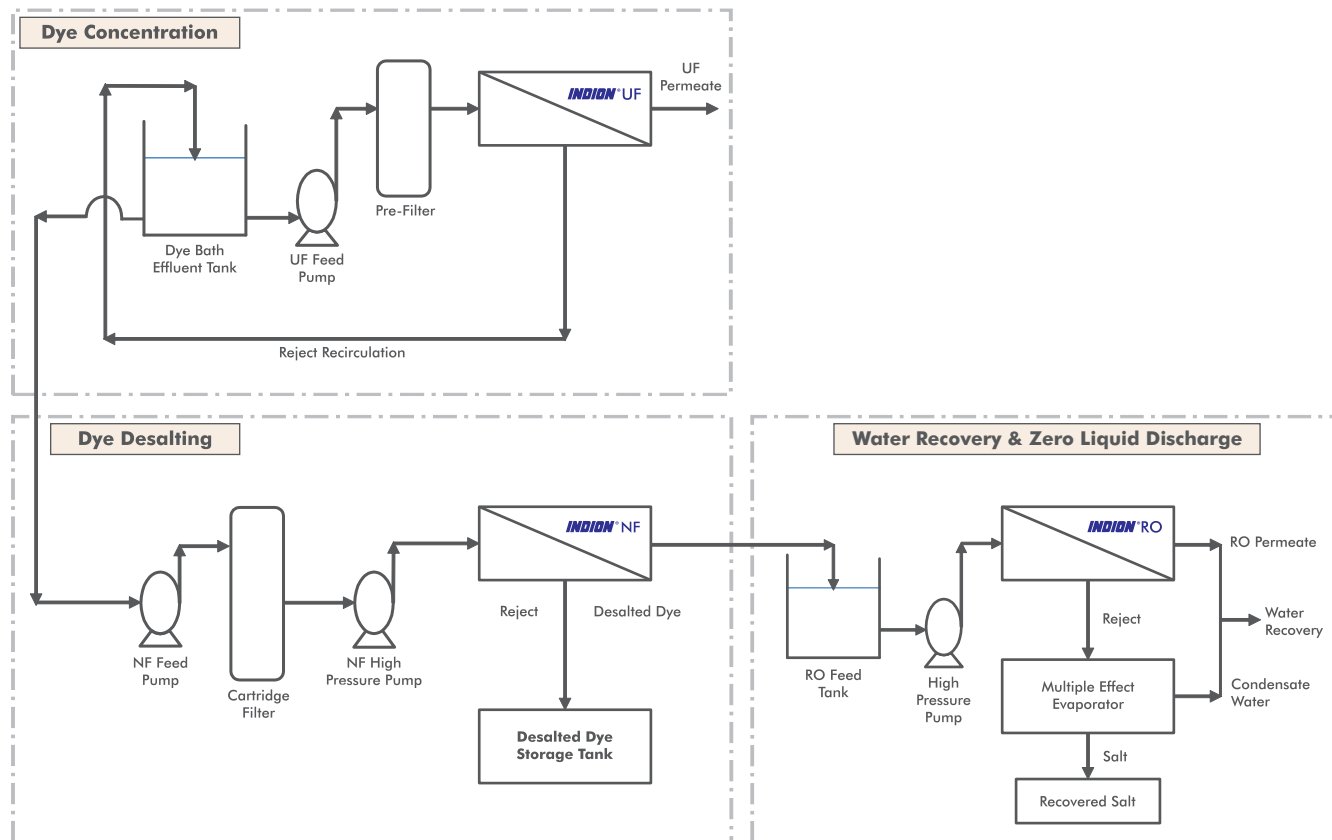

To the best of our knowledge the information contained in this publication is accurate. Ion Exchange (India) Ltd. maintains a policy of continuous development and reserves the right to amend the information given herein without notice. Please contact our regional/branch offices for current product specifications.

INDION® is the registered trademark of Ion Exchange (India) Ltd.



ION EXCHANGE (INDIA) LTD.

Corporate Office

Ion House, Dr. E. Moses Road, Mahalaxmi,
Mumbai - 400011 | Tel: +91 22 6231 2000
E-mail: ieil@ionexchange.co.in

Regional and Branch Offices

Bengaluru | Bhubaneswar | Chandigarh | Chennai
Delhi | Hyderabad | Kolkata | Lucknow | Vadodara
Vashi | Visakhapatnam

International Division

R-14, T.T.C MIDC, Thane - Belapur Road, Rabale,
Navi Mumbai - 400 701 | Tel: +91 22 6857 2400
E-mail: export.sales@ionexchange.co.in

Overseas Offices

Bangladesh | Canada | Indonesia | Kenya
Malaysia | Oman | Portugal | Saudi Arabia | Singapore
South Africa | Sri Lanka | Tanzania | Thailand | UAE | USA

Manufacturing Units

India - Ankleshwar | Hosur | Patancheru | Rabale | Verna | Wada

Overseas - Bangladesh | Indonesia | Saudi Arabia | UAE

All India Service and Dealer Network

www.ionexchangeglobal.com

